



COMMERCIAL RO SYSTEM | DOMESTIC RO SYSTEMS | RO SPARES



Imported, Export and Marketed by
GLOBAL WATER TECHNOLOGIE



Total Care®
(An ISO 9001:2015 Certified Company)

We
THE TOTAL CARE
not only a product
we are

Advisor, Consultant & Gaurdian
of your family's
HEALTH, WEALTH & SECURITY



With more than Two decades experience ,we "Global Water Technologies", have carved a niche for ourselves as one of the leading companies engaged in Manufacturing,wholesaling,trading and supplying of qualitative range of Domestic / Industrial/ Commercial RO System & Spares , LED TV, Air Coolers, CCTV and Other Electronics Goods.

We have targeted all our endeavors towards offering Healthy, Clean, Secure and Pollution free environment to our clients. With this intent to meet potential challenges,we pay considerable significance to innovation.

We have with us a well developed R&D department that is engrossed in carrying out extensive research activities and is backed with profound expertise. They ensure that we do not lack behind in technological aspects in the field our field.

Our team keeps themselves abreast of changing health & environmental issues through in-depth study and testing that further allows us to offer cost-effective and efficient solutions as per specific requirements of our clients.

We are led by Mr. Vijay Singla,who has a rich industry experience in this domain. Under his visionary process guidance and the strong service support provided by our team of experienced industry professionals,we have successfully handled the emerging industrial & commercial RO plant installations and after sales service demands of our customers. Moreover the efforts of our dedicated service support also ensures that we offer these services in both standard as well as customized specifications.

Team " TOTAL CARE "



**HEALTHY
LIVING**

AWARD & CERTIFICATIONS

certified ISO 9001:2015 Company

This responsibility and commitment is practiced and communicated by the top management through:

- Ensuring professional standards and statutory and regulatory requirements are complied with
- Implementation of a policy, which meets the ISO 9001:2015 Quality Management System
- Ensuring staff interact with customers for providing complete turnkey solutions and have successfully commissioned which meet their needs and expectations

awarded by WAPTEMA as State President (Punjab) Since 2016 till now.

Water Purification & Treatment Equipment Manufacturer Association (WAPTEMA) an organization established by Water Industry key players to nourish the industry goals while preserving the most valuable natural resource-Water.

Our CEO **Mr. Vijay Singla** was awarded with the post of "STATE PRESIDENT" in 2016 for his sincere effort & contribution to water purification and filtration industry.

We proude to have such visionary CEO in our organization and stepping up year by year in terms of financial growth as as well as market structure.

NSF & WQA Certified NSF International independently tests and certifies consumer product sectors. WQA Gold Seal Product Certification Program is a scientific method to assure the safety of the products.

More Awards & Certificates

Apart from above certificates and awards, we have bagged more prestigious awards & recognitions





15 Celebrating 15 Years of Excellence



Imported, Export and Marketed by
GLOBAL WATER TECHNOLOGIE

Manufacturing & Assembling

Parts & Components are used in TOTAL CARE RO Plants & Systems are manufactured in house or few are imported from Japan, China & Korea.

We have deployed well trained and qualified staff to assemble our machines and systems.

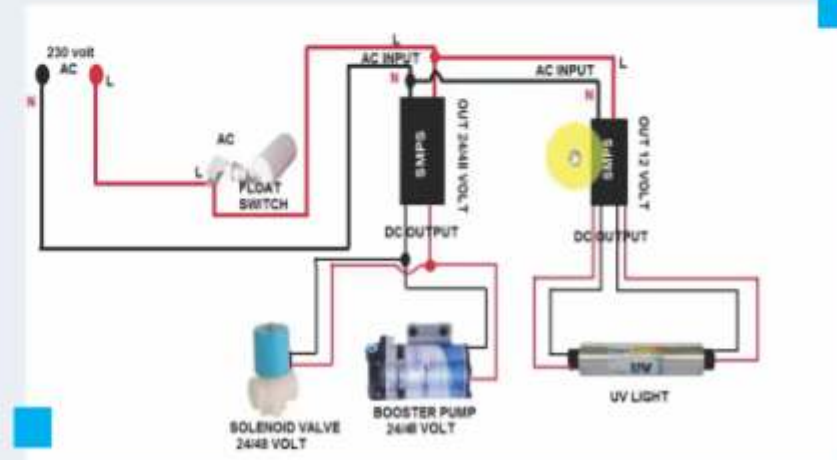

Our Testing Center

Striving for sustainable operational excellence, TOTAL CARE invests in its facilities on an ongoing basis to ensure that we stay at the forefront of fastener manufacturing. Our Technical Center cum Research Facility is geared towards improving our understanding of fasteners and providing a better quality product to the customer. We have installed state of the art testing equipment like Torque testing, Fatigue testing and Vibration testing which are instrumental in keeping the quality of the product in line

Packaging and Logistics

We ship material to the customer on a daily, weekly and monthly basis depending upon the customer's requirement. We use approved logistic providers and freight forwarders to handle our shipments in India.

TOTAL CARE has different packing standards based on customer type and we cater to 2 different customer segments

Aftermarket

Materials are packed in TOTAL CARE labeled boxes and sent to distributors for the aftermarket in India.

Export customers

Materials are packed in corrugated boxes and dispatched on wooden Euro pallets to export customers. These pallets are fumigated, wrapped, labeled and strapped prior to dispatch

We SUPPORT



Imported, Export and Marketed by
GLOBAL WATER TECHNOLOGIE

15 Celebrating
15 Years
of Excellence

OUR Vision
we must stop !!
Wastage of Water
by using efficient **TOTAL CARE** products
it will reduce the wastage of
sweet water & meet
healthy water's NEED

OUR Mission
Healthy Water
is big issue to The World.
we can make our contribution
by providing **SWAKSH JAL**
by total care

OUR Core Values

- Customer Focus**
understand the customer , generate customer enthusiasm ,
act with urgency
- Performance**
reach for excellence , measure progress ,
celebrate success
- Continuous Improvement**
embrace change , apply best practices ,
challenge conventional thinking
- Respect**
act with integrity, Value the contribution of others ,
embrace our global diversity
- Teamwork**
contribute , communicate , Collaborate
- Development**
inventions , implement , improve



PRODUCTS MENU

Total Care[®]
(An ISO 9001:2015 Certified Company)



COMMERCIAL WATER PURIFICATION PLANT & EQUIPMENTS

Available in Capacity
10 LPH to 10,000 LPH



15 Celebrating
15 Years
of Excellence



100% ORIGINAL

24/7 SUPPORT



Imported, Export and Marketed by
GLOBAL WATER TECHNOLOGIE

We assure you
100% quality
satisfaction



SATISFACTION GUARANTEED
Total Care®
सम्पूर्ण सुरक्षा का वादा
100%



CLIENTS:

- ★ GOVT. SECTORS
- ★ BANKS
- ★ CORPORATE HOUSES
- ★ EDU. INSTITUTION
- ★ RELIGIOUS PLACES
- ★ HOSPITALS

Total Care®
(An ISO 9001:2015 Certified Company)



DOMESTIC

WATER PURIFICATION SYSTEM & SPARES

TOTAL CARE has wide range of Domestic RO water purifiers at different price tag. In its domestic range, we have wall mounting, table top and under the sink model.

These Domestic RO Water Purifiers are meant exactly for your home. They have up to 8 stages of purifications and features like RO+UV+UF+Alkaline Technology intact with them.



RO SPARES

*we assure you
100% quality
satisfaction*



- RO Booster Pumps
- Domestic RO Cabinets (Body)
- Domestic RO Membranes
- UV Lamp
- UV Barrel
- UV Choke
- Adaptors and SMPS
- Filter Housings
- Inline Filters
- Filter Cartridges
- Domestic RO Fittings

- RO Fittings
- Inlet Fittings
- Divertor Valve
- RO Piping
- Solenoid Valves (S.V.)
- Clamps and Brackets
- RO Stands and Skids
- Taps and Faucets
- Miscellaneous Accessories



Benefits of H² Infused Alkaline Water

- * Increase in energy
- * Improve Cognitive Function
- * Reduced muscle Fatigue
- * Improves your hydration
- * Incredible antioxidant power
- * Decrease pain and inflammation
- * Neutralize harmful free radicals



13 STAGES OF FILTRATION

- * Cutting edge Filtration to give you the Healthiest Water that is also Pristine and ultra - clean !
- * Rigorously tested in an independent, EPA - certified laboratory.
- * 99.9% removal of virtually all contaminants - even tough to remove pharmaceuticals, heavy metals, arsenic, and VOCs.



| | TC-MELO II | TC-ATHEN H2 | TC-VOSTA H2 | TC-ENAG-SD 501 | TC-ENAG - K-8 | TC-LIFE - MXL-7 | TC-LIFE - MXL-9 |
|------------------------------------|--|--|--|---|---|--|--|
| Number of Plates | 5 | 7 | 9 | 7 | 8 | 7 | 9 |
| Plate Design | Platinum / Platinum SmartDesign Efficient Electrodes | Platinum / Platinum SmartDesign Efficient Electrodes | Platinum / Platinum SmartDesign Efficient Electrodes | Dated Technology Platinum / Platinum Plate Design | Dated Technology Platinum / Platinum Plate Design | Dated Technology Platinum / Platinum Plates requiring excess power with plate Degradation after 18 month | Dated Technology Platinum / Platinum Plates requiring excess power with plate Degradation after 18 month |
| Power Efficiency | 150W | 150W | 150W | 235W | 230W | 450W | 404W |
| Highest PH Performance | 10.8 | 11.4 | 12 | 10.8 | 11.2 | 9.9 | 10.8 |
| Lowest PH Performance | 2.6 | 2.3 | 2.0 | 2.8 | 2.4 | 4.2 | 3.8 |
| ORP Performance | -760 | -833 | -920 | -450 | -580 | -340 | -640 |
| H2 Performance at Drinking PH of 9 | 1.1ppm | 1.3 ppm | 1.6 ppm - Top Performing H2 Ionizer In the World! | 0.2 ppm | 0.4 ppm | 0.4 ppm | 0.5 ppm |
| Premium Dual Filtration | 2 Premium Internal Filters + Custom Per-Filtration options | 2 Premium Internal Filters + Custom Per-Filtration options | 2 Premium Internal Filters + Custom Per-Filtration options | 1 Premium Filter | 1 Premium Filter | 2 Basic Internal Filters + custom per-Filtration options | 2 Basic Internal Filters + custom per-Filtration options |
| Ultrawater Filters Included | Premium Ultrawater Filters | Premium Ultrawater Filters | Premium Ultrawater Filters | Basic Charcoal Filter | Basic Charcoal Filter | Uses Basic Vitamin C Filters | Uses Basic Vitamin C Filters |
| DARC Cleaning | YES | YES | YES | NO | NO | NO | NO |
| Auto Adjust | NO | YES | YES | NO | NO | NO | NO |
| SMPS Power | Next Generation SMPS | Next Generation SMPS | Next Generation SMPS | SMPS | SMPS | SMPS | SMPS |
| Warranty | full 5 years | full 5 years | full 5 years | full 5 years | NO | NO | NO |
| UK service Centre | YES | YES | YES | Germany | Germany | NO | NO |
| Price | £1,199 | £1,499 | £1,799 | £2,819 | £3,699 | £1,395 | £1,899 |
| Country of Design / Origin | USE/ Korea | USE/ Korea | USE/ Korea | Japan | Japan | USE/ Korea | USE/ Korea |
| Dimensions | 32 x 37 x 14cm (WxHxD) | 32 x 37 x 14cm (WxHxD) | 32 x 37 x 14cm (WxHxD) | 25 x 37 x 14cm (WxHxD) | 25 x 37 x 14cm (WxHxD) | 30 x 38 x 17cm (WxHxD) | 30 x 38 x 17cm (WxHxD) |
| Weight | 5.7kgs | 5.7kgs | 5.7kgs | 6.3kgs | 6.3kgs | NA | NA |
| Year Introduced | 2018 | 2018 | 2018 | 2004 | 2014 | 2017 | 2017 |
| Installation Options | 3 - Options - Under Top, Direct Plumb | 3 - Options - Under Top, Direct Plumb | 3 - Options - Under Top, Direct Plumb | 3 - Options - Under Top, Direct Plumb | 3 - Options - Under Top, Direct Plumb | 3 - Options - Under Top, Direct Plumb | 3 - Options - Under Top, Direct Plumb |





We " TOTAL CARE "

offer our clients a complete range of

Durable, Advanced and Efficient **WATER DISPENSERS !**

with Hot & Cold along with and without storage options.

Our Dispenser meets the requirements of all its clients from offices, institutions or homes.



| MODELS | Total Care BLUE | Total Care GOLD | Total Care FROSTY | Total Care SUPREME | Total Care JUMBO | Total Care DIAMOND |
|---------------------------------|---------------------------|--------------------------|--------------------------|--------------------------|--------------------------|--------------------------|
| No.of Faucets | 2 | 3 | 2 | 2 | 2 | 3 |
| Floor Standing | Yes | Yes | Yes | Yes | Yes | Yes |
| Floor Standing+ Storage Cabinet | No | Yes | No | No | No | No |
| Floor Standing+ Cooling Cabinet | No | Yes | No | No | No | No |
| Floor Standing for Purifier | Yes | Yes | No | Yes | No | No |
| Table Top | Yes | Yes | No | No | No | No |
| Normal & Cold Option | Yes | Yes | No | Yes | No | No |
| Cold Storage Capacity | 3.5Litres | 4.0 Litres | 3.5 Litres | 8 Litres | 8 Litres | 13 Litres |
| Power Source | 220V/1P/50Hz | 220V/1P/50Hz | 220V/1P/50Hz | 220V/1P/50Hz | 220V/1P/50Hz | 220V/1P/50Hz |
| Power Cold | 110Watts | 110Watts | 120Watts | 120Watts | 150Watts | 150Watts |
| Power Hot | 500Watts | 500Watts | 500Watts | 500Watts | 500Watts | 500Watts |
| Cold Temperature Range | 7 ~13°C | 7 ~13°C | 7 ~13°C | 7 ~13°C | 7 ~13°C | 7 ~13°C |
| Refrigerant | R 134a(CFC Free) | R 134a(CFC Free) | R 134a(CFC Free) | R 134a(CFC Free) | R 134a(CFC Free) | R 134a(CFC Free) |
| Cooling Capacity | ≤12°C,2.5Litres/hr | ≤12°C,2.5Litres/hr | ≤12°C,2.5Litres/hr | ≤12°C,2.5Litres/hr | ≤12°C,2.5Litres/hr | ≤12°C,2.5Litres/hr |
| Heating Capacity | ≤90°C,5 Litres/hr | ≤90°C,5 Litres/hr | ≤90°C,5 Litres/hr | ≤90°C,5 Litres/hr | ≤90°C,5 Litres/hr | ≤90°C,5 Litres/hr |
| Condenser | Static | Static | Static | Static | Fan Cooled | Fan Cooled |
| External Cabinet | ABS Plastic + Metal Sides | ABS Plastic+ Metal Sides | ABS Plastic+ Metal Sides | ABS Plastic+ Metal Sides | ABS Plastic+ Metal Sides | ABS Plastic+ Metal Sides |
| HxWxD(mm) Floor Standing | 920x330x330 | 950x340x310 | 920x330x330 | 920x330x330 | 1120x330x330 | 1150x350x350 |
| HxWxD(mm) Table Top | 500x330x300 | 550x340x310 | ----- | ----- | ----- | ----- |
| Net Weight (kg) Floor Standing* | 15 | 17 | 18 | 19 | 21 | 28 |

Total Care
(An ISO 9001:2015 Certified Company)



WE SUPPORT





Medical Device Manufacturer



CE - LVD



CE - EMC

सम्पूर्ण सुरक्षा का वादा



CE - LVD



CE - EMC



FCC



Design Patent-R series



Design Patent-R series



EAC Russia Certificates

★ Our Imported products have many necessary certificates , which are required by the department



FCC



ISO 9001



ISO 14001

★ Our Imported products have many necessary certificates , which are required by the department



POLAND ATEEST HIGIENICZNY



SGS BPA FREE



Water Purifier Manufacturer



EAC Russia Certificates



Promising Export Enterprise



Promising Export Enterprise(KOR)



Total Care®

(An ISO 9001:2015 Certified Company)



GLOBAL WATER TECHNOLOGIES (Regd.)

(An ISO 9001:2015 Certified Company)

HEAD OFFICE

B-37/109, St. No. 3, Jagdish Nagar,
Dugri, Ludhiana - 147003, (Pb.) India.
Contacts : +91 161 2491216, 92164 60216

PATIALA OFFICE

SCF-13, S.S.T Nagar, Opp. Hotel Eqbal Inn.,
Rajpura Road, Patiala-147001(Pb.) India.
+91 175 5005538

JALANDHAR

EG-934, Prem Nagar, Nr. Wattan Pink Plaza,
Jalandhar - 144001 (Pb.) India.
+91 79863 13020

e-mail : info@globalwatertech.co.in

web.: www.globalwatertech.co.in

